

ELECTRIC NETWORK RELATED PROBLEMS OF THE APPLICATION OF REGULATED ELEVATOR DRIVES OPERATED WITH FREQUENCY CONVERSION

Zoltán KVASZNICZA* and Béla KULCSÁR**

*Institute of Information Technology and Electrical Engineering
University of Pécs, Pollack Mihály Faculty of Engineering
H-7624, Pécs, Boszorkány u. 2. Hungary
e-mail: kvasznicza@witch.pmmf.hu

**Department of Building Machines, Materials Handling Machines and Manufacturing Logistic
Budapest University of Technology and Economics
H-1111 Budapest, Műegyetem rkp. 3. Hungary
e-mail: kulcsar-bela@eagt.bme.hu

Received: Oct. 25, 2005

Abstract

In our days application of the so-called voltage-controlled drives is driven into the background in the field of elevator controls and in some cases the variable frequency drive is unduly preferred. The latter one is significantly more sensitive to the disturbances on the mains and at the same time emits disturbances into the mains as well.

For perfect operation low frequency conducted and radiated disturbances have to be decreased by filter units of optimum design and the traditional aspects of elevator drive installations and operations have to be reevaluated.

Keywords: elevator drives, frequency converters, mains disturbances.

1. Using Asynchronous Motors in Elevator Drives

In speed-regulated elevator drives (drives with one or two speeds) almost exclusively asynchronous motors with short-circuit rotors are used: they are highly reliable and have a low maintenance need.

In case of elevators of higher speeds the adequate travelling comfort and delivering capacity are assured by speed regulated asynchronous motors. Drives featuring regulation only during the braking period solve the task of a precise floor positioning with the help of eddy-current break motors or by operating the drive motor in dynamic direct current braking mode. In case of drives regulated during the whole travel path the speed regulation during start-up and during the steady-state travelling period can be realized by modifying the stator voltage of the asynchronous motor. Braking of the cabin can not be realized with this method. Regulated braking can be achieved by supplying the winding with a higher pole number with direct current during the braking phase [1].

2. Asynchronous Motor Elevator Drives with Voltage Inverter

As a result of the recent development of semiconductor technology the practical application of frequency-controlled asynchronous motor drives has become economical in the field of elevator industry as well. Due to the regulation of the supply voltage and frequency of the a.c. motor the speed of the driving machine can be infinitely modified in these drives and without losses during the whole travelling period. Speed-regulated elevator drives operated by frequency conversion can be divided into two groups:

- Drives operated with U_1/f_1 control are those lent from the industrial frequency converters and can only restrictedly be used as elevator drives up to a speed of about 1.2 m/s.
- Elevator drives operated with flux vector control (field-oriented control) enabling the asynchronous machine to behave like a direct current motor with separate excitation being able to be excellently controlled and giving the whole torque during stationary condition as well.

Semiconductor devices applied for the contemporary control of the supply frequency (f_1) and the supply voltage (U_1) are of complex structure and can have different designs. However, all of the frequency converters with the so-called intermediate direct current circuit follow the principle shown in *Fig. 1*.

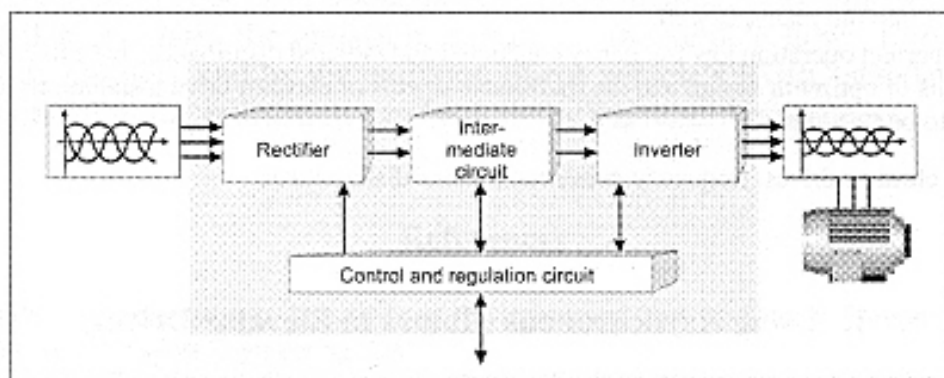

Fig. 1. Theoretical build-up

The most commonly used version of frequency converters are those having voltage inverter with a possible realization shown in *Fig. 2*.

A controlled rectifier (type 3F2U6Ü) is connected to the electric mains supplying the capacitor of the intermediate circuit. The capacitor is loaded when the momentary value of the rectifier is higher than that of the capacitor. During start-up of the frequency converter the ignition delay angle of the bridge decreases gradually and therefore the high starting current can be avoided. During normal operation no ignition delay is used – as a consequence no harmonics are produced. The intermediate circuit serves as a separation stage between the rigid mains and the variable output of the frequency converter. The capacitor with high $C1$ capacitance

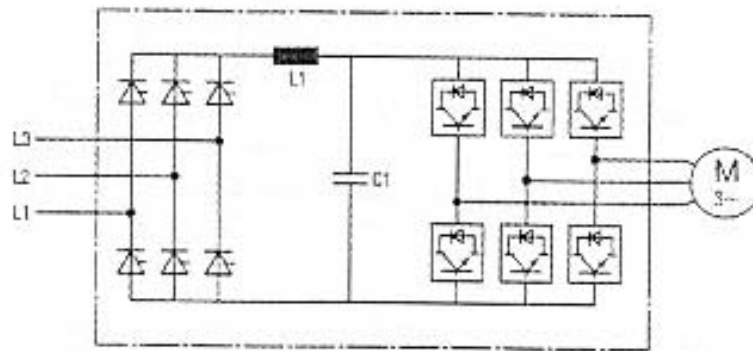

Fig. 2. Basic structure of a frequency converter with voltage inverter

value in the intermediate circuit performs energy storage. Within a period of the voltage wave the capacitor supplies the motor with energy when the momentary value of the mains is lower than that of the intermediate circuit. Due to the high capacitance value the voltage of the intermediate circuit decreases very little during a voltage wave period. As a consequence of the above the capacitor can absorb energy from the mains only during the short time spans around the peak value of the mains voltage. The mains recover the used energy by current pulses with high harmonic content.

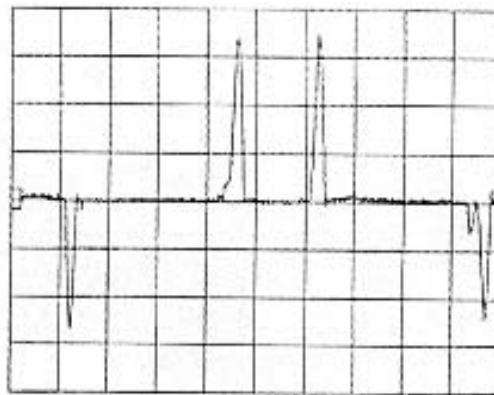

Fig. 3. Mains current without L_1 choke

Intermediate circuit of frequency converters of high quality (prices) contains also a filter choke (L_1). This choke serves for the elongation of the current flow on the mains side. This results in a significant decrease in the current's peak value and harmonic content (Figs. 3-4).

The inverter converts the direct current of the intermediate circuit to three phase alternating current with variable amplitude and frequency. Formerly transistors were used for this purpose, but nowadays almost exclusively IGBT (Insulated Gate Bipolar Transistor) units are used. These units compose a so-called IPM (Intelligent Power Module) consisting six IGBT elements, protective diodes, control and safety circuits. This structure makes manufacture of frequency converters

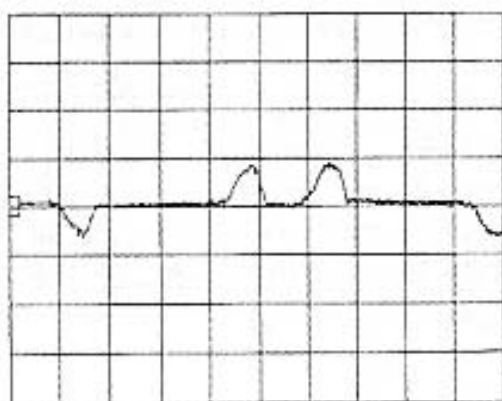

Fig. 4. Mains current with L_1 choke

much easier but, at the same time, makes their servicing and repair more expensive because the whole of the IPM unit must be replaced and this is the most expensive part of the equipment.

Changing the voltage and frequency is normally realized by pulse width modulation (PWM). There are a lot of solutions to this task depending on the design and producer of the device affecting the characteristics of the frequency converters and of the asynchronous motors supplied by them.

3. Interaction of Mains Disturbances and Elevator Controls

In our days a significant change can be observed in the composition of electric energy consumers. There are more and more up-to-date industrial, communal and lighting devices as well as variable frequency elevator drives connected to the electric network which behave as so-called non-linear loads.

Changes in the structure of the consumers react onto the quality parameters of the electric energy and on the network and affect it.

The standard MSZ EN 50160 [6] describes the voltage parameters of electric energy and the quality parameters affected by the consumer devices – causing operation disturbances in elevator controls – and can be improved by the reconstruction of the consumer distribution network.

These parameters are

- amplitude and changes of the supply voltage,
- harmonic voltages,
- flicker.

Variable frequency drives are very sensitive to the value (amplitude) of the mains voltage. High starting current and the resulted voltage drop cause problems mainly in case of elevator drives of high power. In case of a well dimensioned mains cable the voltage at the supply end of the drive is not allowed to decrease

under 400 V – 10%. (Phase voltage is not allowed to decrease under 207 V.) If voltage drop is higher than that allowed, this can result in serious problems in the operation of variable frequency drives. Manufacturers guarantee perfect operation only in case of voltages within 400 V \pm 10%.

Voltage curve of an elevator with a payload of 2500 kg, with a speed of 1.6 m/s and driven by a 22 kW motor shows, that voltage drops caused by start-ups – in case of full load – remain within the prescribed range (Fig. 5).



Fig. 5. RMS value of the phase voltages

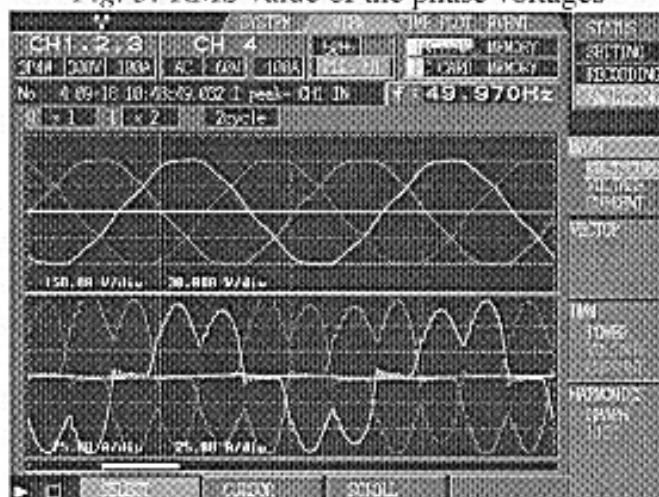

Fig. 6. Voltage and current curves of the mains

Up-to-date elevator control and drive systems are nearly exclusively designed using microcomputers. These systems feature low control energy level and high intervention energy level. In excess to the above the so-called shared intelligence systems are even more used (e.g. tableaus and the drive are connected to the control through an RS 485 interface) with a communication of a very low energy level among them.

These modern control systems are very sensitive to mains disturbances. Mu-

tual induction of harmonic currents can cause problems in the data transmission. On the other hand variable frequency drives are also sources of serious disturbances emitted onto the electric network.

Consumer voltage is determined by the supply voltage at the consumer end and the voltage drop between the supply and consumer ends. Voltage drop is generated by the consumer current flowing through the cable impedance having although a periodic but non-sinusoidal wave form in case of non-linear loads (*Fig. 6*). This non-sinusoidal current results in a non-sinusoidal voltage drop. This voltage causes distortions in the consumer current. Distortion can be characterized with the Total Harmonic Distortion (THD_U) factor

$$THD_U = \frac{\sqrt{\sum_{k=2}^{\infty} U_k^2}}{U_1} \cdot 100\%.$$

In case of elevator controls it is very important that the equipment does not emit network disturbances above the allowed level.

According to the standard MSZ EN 50160:2001 [6] the THD_U value is not allowed to exceed 8% including all the harmonics up to 40th one. Harmonic content of the input current can be decreased using low frequency filters (non-saturating chokes). For conducted disturbances (150 kHz - 30 MHz) the standard MSZ EN 12015:2001 [5] contains prescriptions. Conducted disturbances can be decreased with high frequency filters. For lowering the radiated disturbances (30 MHz - 1 GHz) the motor cable is to be screened in all cases. The adequate design of the earthing is highly important.

The electric characteristics of a frequency converter developed for elevator drives equipped with appropriate filters have been measured.

Current drawn from the mains is periodic but non-sinusoidal containing harmonics. In *Fig. 7* it can be seen that in case of harmonic currents those of 0 sequence (3, 9, 15, ...) are of low amplitudes so they do not load the neutral wire. The values of negative sequence harmonics (5, 11, 17, ...) are higher, however, causing no excess load on the neutral wire.

Distortion of the supply voltage generated by the harmonics in the current remains within the allowed range, $THD_U = 3.21\% < 8\%$ (*Fig. 8*).

Fig. 9 shows that this type of drives works with very good power factors ($\cos \varphi > 0.9$). This means energy saving, the drive does not load the network with unnecessary reactive power.

The measured conditions can be achieved only with low and high frequency filters installed at the supply end.

4. Most Important Practical Aspects of the Installation of Elevator Drives

- Voltage drops generated by starting currents and harmonics are to be lowered by increasing the wire cross section.

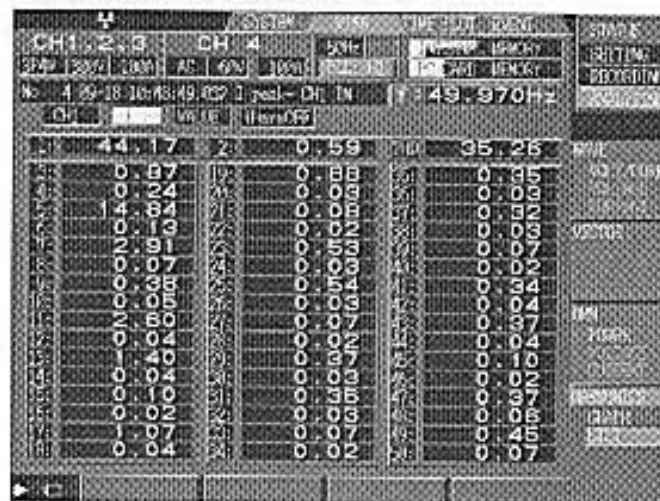

Fig. 7. Values of the harmonics of the mains current

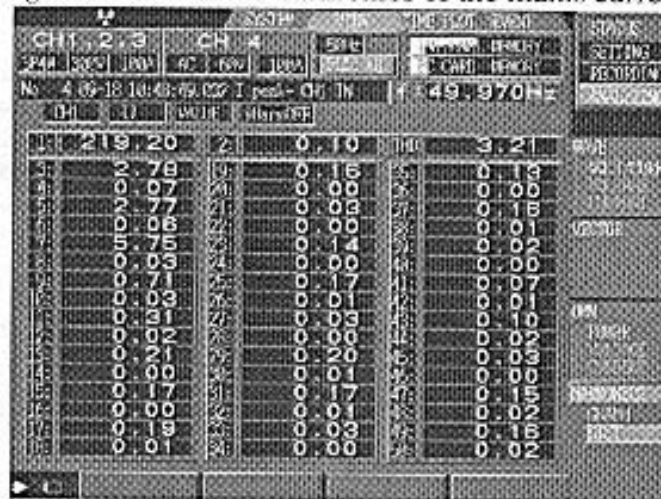

Fig. 8. Amplitudes of the harmonics of the mains voltage

- Cross section of the phase wires and the neutral wire has to be increased by about 50% related to that dimensioned for linear loads [3]. (During dimensioning currents flowing in AC3 and AC4 modes are also to be taken into account.)
- With the knowledge of the non-linear consumer composition and of the network the system is to be examined for possible harmonic problems. Solutions are to be found (installing low and high frequency filters).
- The system having already been installed has to be tested for the possible operating modes by measurements.
- Earthing systems have to be designed and installed thoroughly.
- For lowering the radiated disturbances screened motor cables have to be used.

In case of electric networks designed according to the above the control and data transmission systems of elevators normally operate perfectly.

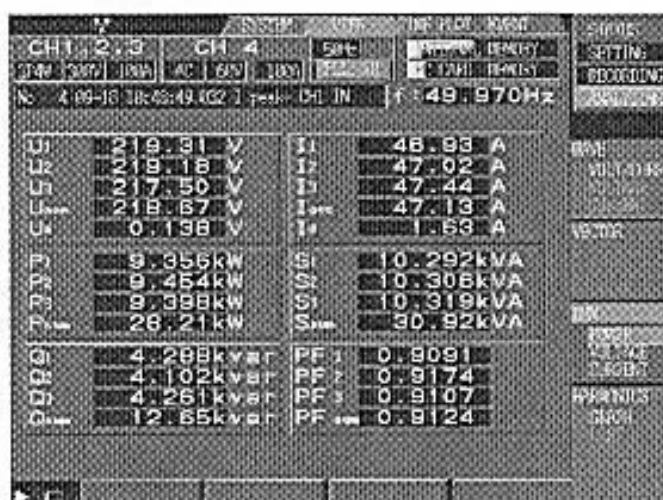

Fig. 9. Power taken up from the mains

5. Conclusion

Non-linear electric consumers – including elevator equipment – installed in buildings equipped with up-to-date devices and technologies (office building, hotels, educational institutions) derogate the parameters of the electric network. These phenomena have to be remedied. On one hand it is not enough to dimension the consumer's electric network based on the linear consumers loads but also non-linear loads have to be taken into account for avoiding mains interference and overloads. On the other hand consumer devices have to be equipped with filters suppressing or decreasing disturbances emitted to the mains.

The example described above demonstrates that in case of drives with higher power ($P_c = 22$ kW) as well, electric parameters of frequency converters with adequate filters remain within the limits prescribed by the relevant standards.

References

- [1] APATINI, K. – BÉRCES, G. – HORVÁTH, I. – MAKOVSKY, G. – NÉMETH, Z. – TARNIK, I., *Operating and Repair of Elevators and Moving Stairs* (in Hungarian), Műszaki Könyvkiadó, Budapest 1983, pp. 100–134.
- [2] BIMAL, K. B., *Power Electronics and Variable Frequency Drives*, IEEE Press, 1997, pp. 138–276.
- [3] DÁN, A., *High Quality Electric Energy with Increased Copper Cross Section* (in Hungarian), Magyar Rézpiaci Központ, Budapest 2003.
- [4] HALÁSZ, S. – HUNYÁR, M. – SCHMIDT, I., *Automated Electric Drives II.* (in Hungarian), Műegyetemi Kiadó, Budapest, 1998, pp. 11–115.
- [5] MSZ EN 12015:2001, *standard*.
- [6] MSZ EN 50160:2001, *standard*.
- [7] *Wissenwertes über Frequenzumrichter*, Danfoss A/S, 1997, pp 53–80.